

ILTEC – Under bath cooling in a Mitsubishi Converting Furnace

Dr. Martina Hanel, METTOP GmbH

European Metallurgical Conference
Emc2023

EMC sponsored by:

KÜTTNER

 **NICKELHÜTTE AUE**
1909 1990 2023

wieland **SMS**  **group**

HATCH **BEFESA**

 **Aurubis**
Metals for Progress

Metso:Outotec

GLENCORE
Nordenham

organized by

 **GDMB**
Gesellschaft der
Metallurgen und Bergleute e.V.

Mettop Group Presentation Organization Chart



Dr. Iris Filzwieser
Dr. Andreas Filzwieser

mettop



Mettop Group Presentation

Overview Products and Services



Non-ferrous metals units

Products:

- ◆ PolyCONVERT[®]
- ◆ PolyREFINE[®]
- ◆ HENRI[®]
- ◆ Gas Purging Systems
- ◆ Coolers

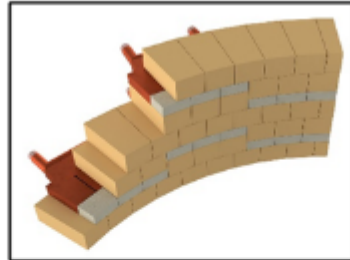

Refractories non-ferrous

Products:

- ◆ 3D Engineering + supply
- ◆ CFD modeling
- ◆ HT-calculations
- ◆ EXP-calculations

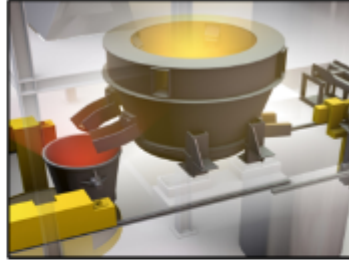

E-waste recycling UrbanGold

Products:

- ◆ Process Engineering
 - ◆ UG Compact
 - ◆ UG Flex
 - ◆ UG Classic
- ◆ Market Studies



Tankhouse technology

Products:

- ◆ METTOP-BRX[®] Technology
- ◆ Cathode spacers
- ◆ Complete Tankhouse



ILTEC for vessel cooling

Products:

- ◆ IL-B2001[®]
- ◆ Ionic Liquid Technology for vessel cooling
- ◆ Furnace integrity optimization

Research & Development & Innovation

DigMet



Overall Process & Technology Consulting

Field Studies & Trainings

Process and 3D Plant Engineering



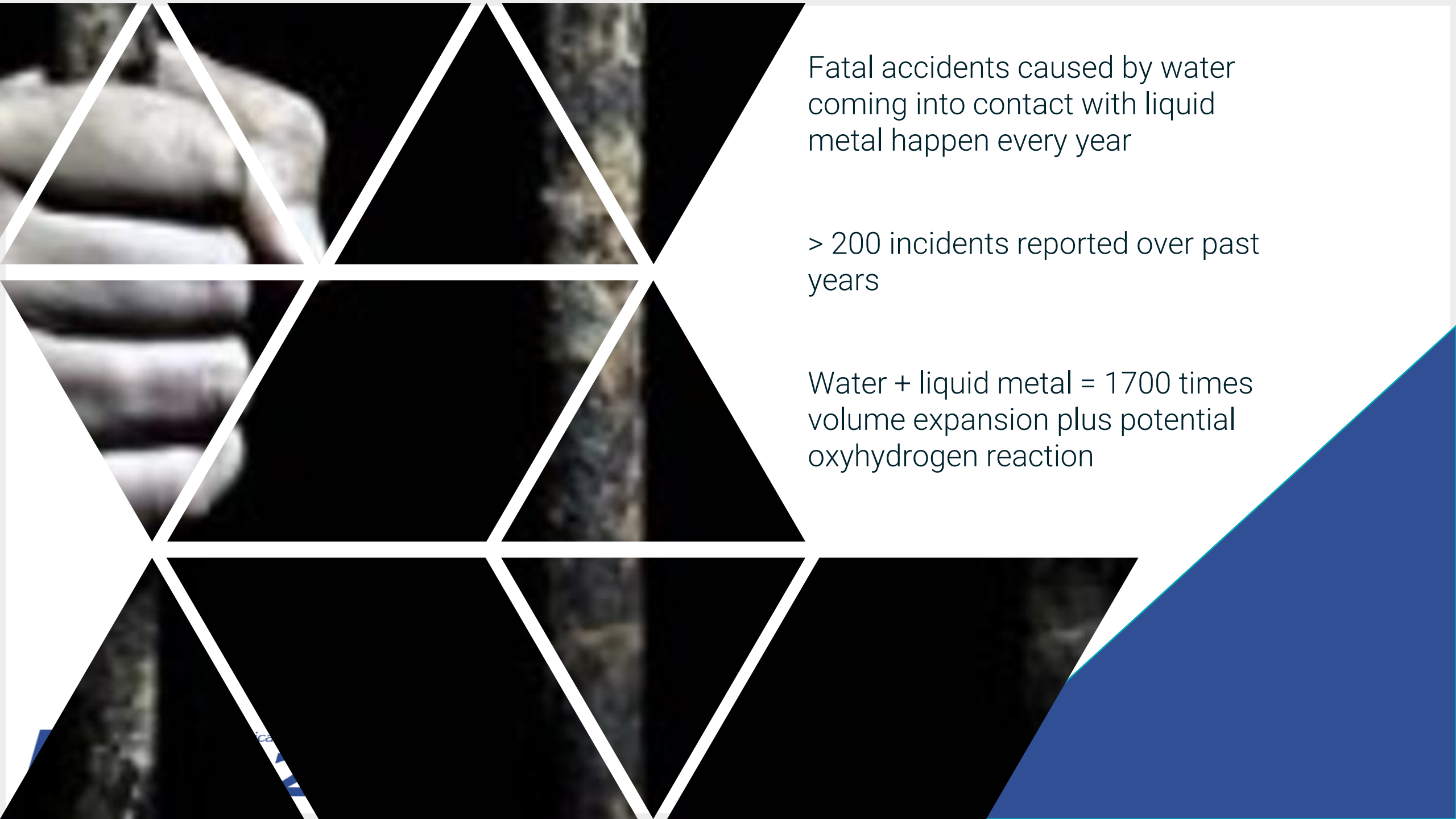

Fatal accidents caused by water coming into contact with liquid metal happen every year

> 200 incidents reported over past years

Water + liquid metal = 1700 times volume expansion plus potential oxyhydrogen reaction

ILTEC Technology

The future in furnace cooling



- Revolutionary technology in vessel and equipment cooling
- Replacement of water for safe vessel cooling
- Injection tests in Cu and steel making units

ILTEC Technology

Re-defining safety

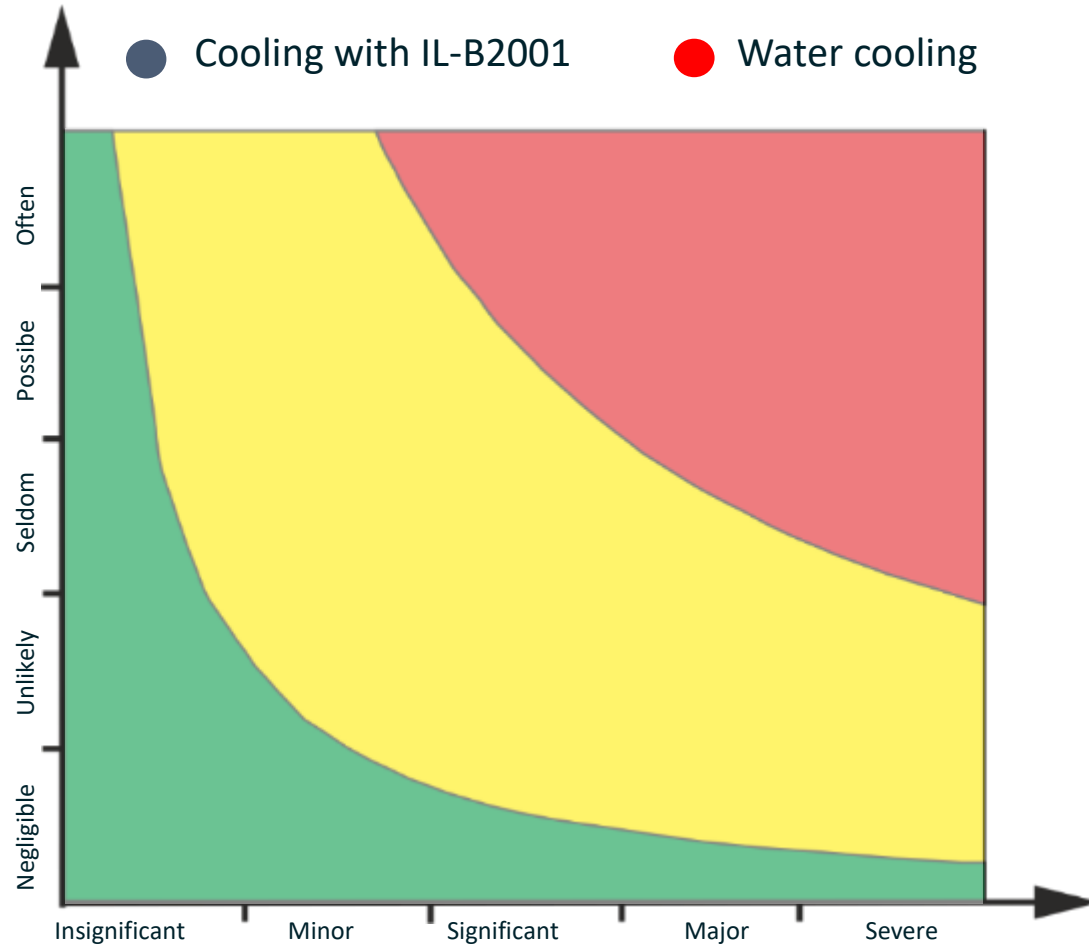

- ◆ Accidents occur
- ◆ When water is replaced by IL-B2001-> explosion free environment
- ◆ Likelihood of incident comparable
- ◆ Consequences minimized

ILTEC Technology

Characteristics of new cooling medium



- ◆ No explosive reaction at contact with liquid metal
- ◆ Not harmful or toxic even when decomposed – tested at proionic and at Montanuniversität Leoben; REACH registered
- ◆ Non corrosive - chlorine free; production procedure – production route patented by Proionic ; no restrictions for metal body and seals (EXEPTION: Viton sealing)
- ◆ Sufficient cooling due to sufficient heat removal – proven at FH Wels and at our reference plants
- ◆ No altering or change in behaviour - if there is no contact with hydrogen or water

ILTEC Technology

Characteristics of new cooling medium

	Symbol	Value	Unit	Range
Operation temperature		50-200	[°C]	$\Delta T = 150 \text{ }^\circ\text{C}$
Short term stability		250	[°C]	
Decomposition temperature		450	[°C]	
Minimum operation temperature		-10	[°C]	
Crystallization temperature		-30 – -40	[°C]	
Density	ρ	1.25 – 1.14	[kg/dm ³]	50 – 200 °C
Specific heat capacity	c_p	1.70 – 1.99	[J/gK]	50 – 200 °C
Dynamic viscosity	η	20 – 5	[mPa·s]	50 – 200 °C
Electrical conductivity	κ	30 – 130	[mS/cm]	50 – 200 °C

$$Q \text{ [W]} = \dot{m} \text{ [m/s]} \cdot c_p \text{ [J/gK]} \cdot \Delta T \text{ [K]}$$

ILTEC Technology

Hardware – compact and small units



- ◆ Tank filled with IL-B2001, freeboard purged with nitrogen to prevent hydration
- ◆ Two identical pumps (one for standby)
- ◆ Two heat exchangers connected with secondary cooling circuit (one for standby)
- ◆ Measurement of temperature, flow, pressure and differential pressure

ILTEC Technology

Hardware – distribution units for large scale application



ILTEC Technology

Possible applications of ILTEC Technology with IL-B2001

Safety

- ◆ Replacing water with IL-B2001
- ◆ Examples: sidewall cooling, tap holes
- ◆ Reference: tap hole AM in Bremen

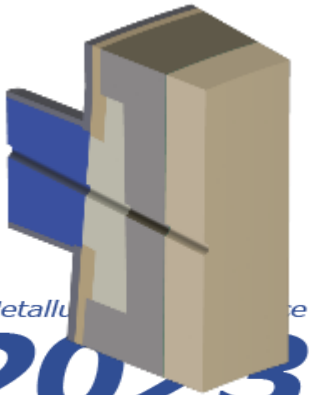

New cooling applications

- ◆ New cooling panels
- ◆ Examples: underbath cooling, instruments, lances, tuyers, PS-converter, perm. electrode
- ◆ Reference: Vessel cooling at Nyrstar

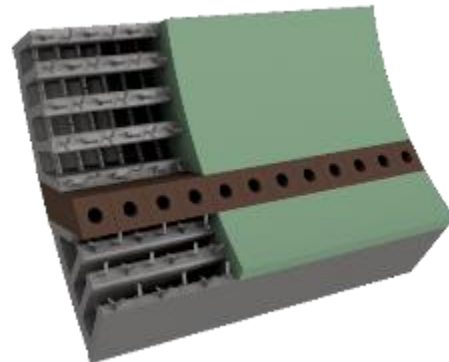

New processes

- ◆ New processes due to ILTEC
- ◆ Example: HENRI reactor for e-waste recycling

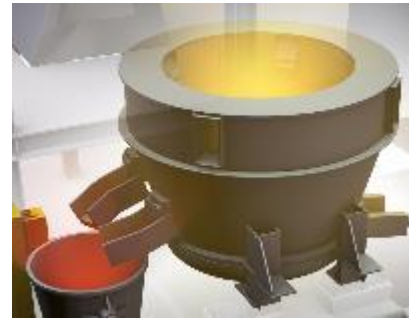

Heat recovery

- ◆ Example: ER systems for EAF, BOF, CC, SAF, cooling systems

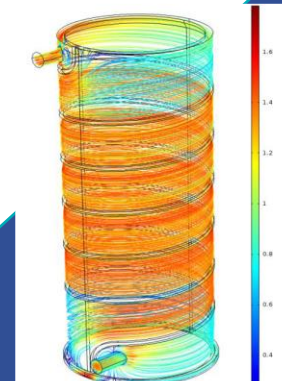

ILTEC Technology

Possible applications of ILTEC Technology with IL-B2001

Sidewall cooling
under-bath

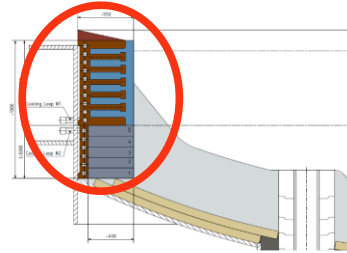

Tap blocks

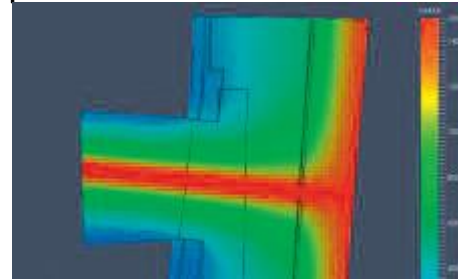

Runners



Bottom electrodes

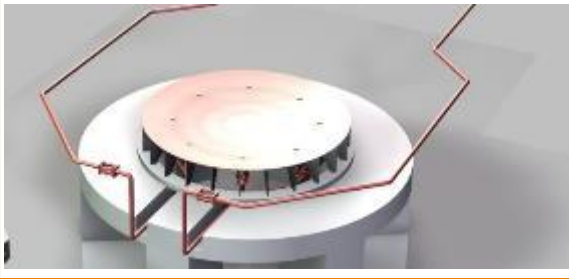

Reactor cooling



Offgas ducts



Instruments

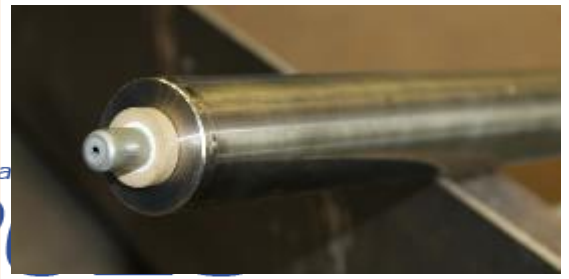

Lances



Purging systems

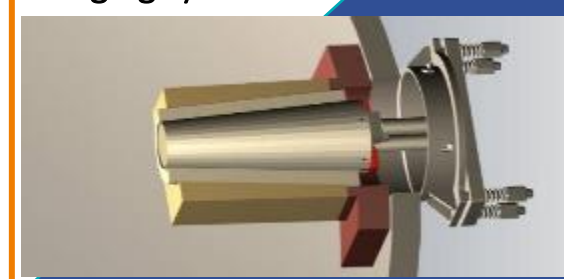

ILTEC Technology

References of industrial scale use (as of October 2022)

Application	Benefit	Supply lines	Overall flow capacity	Country	Start Up
Cooling of shaft part of plasma furnace	Guaranteeing higher temperature inside the furnace for preventing corrosion from sulfuric acid	3	30 m ³ /h	Norway	January 2015
Blast furnace tap hole	Increasing safety	2	30 m ³ /h	Germany	October 2015
Test for cooling EAF bottom shell	Increasing the lifetime of refractory beneath bath level	2	20 m ³ /h	Germany	Tests performed in Summer 2017
Cooling of pipes of copper coolers during the casting process	Increasing process safety and improve copper cooler quality	4	50 m ³ /h	Spain	January 2018
Cooling of connection flanges at the RH degassing vessel	Increasing process safety and prevent warping	2	15 m ³ /h	Austria	June 2018
Side wall cooling in cyclone furnace	Side wall cooling for improved lifetime in highly stressed burner areas	1	10 m ³ /h	Denmark	Test in Summer 2019
Tap hole cooling at slag cleaning furnace	Increased safety	1	10 m ³ /h	Germany	Test in Summer 2019
Lance cooling at TBRC converter	For submerged oxygen blowing	1	10 m ³ /h	Korea	October 2020
ZnMg bath cooling	Longer campaigns; temperature regulation of zinc bath	3	40 m ³ /h	Hungary	Summer 2023
Sidewall cooling of Mitsubishi Converting Furnace	Safe cooling of copper elements below bath level	12	100 m ³ /h	South Korea	March 2023

ILTEC Technology

Installation at Mitsubishi furnace

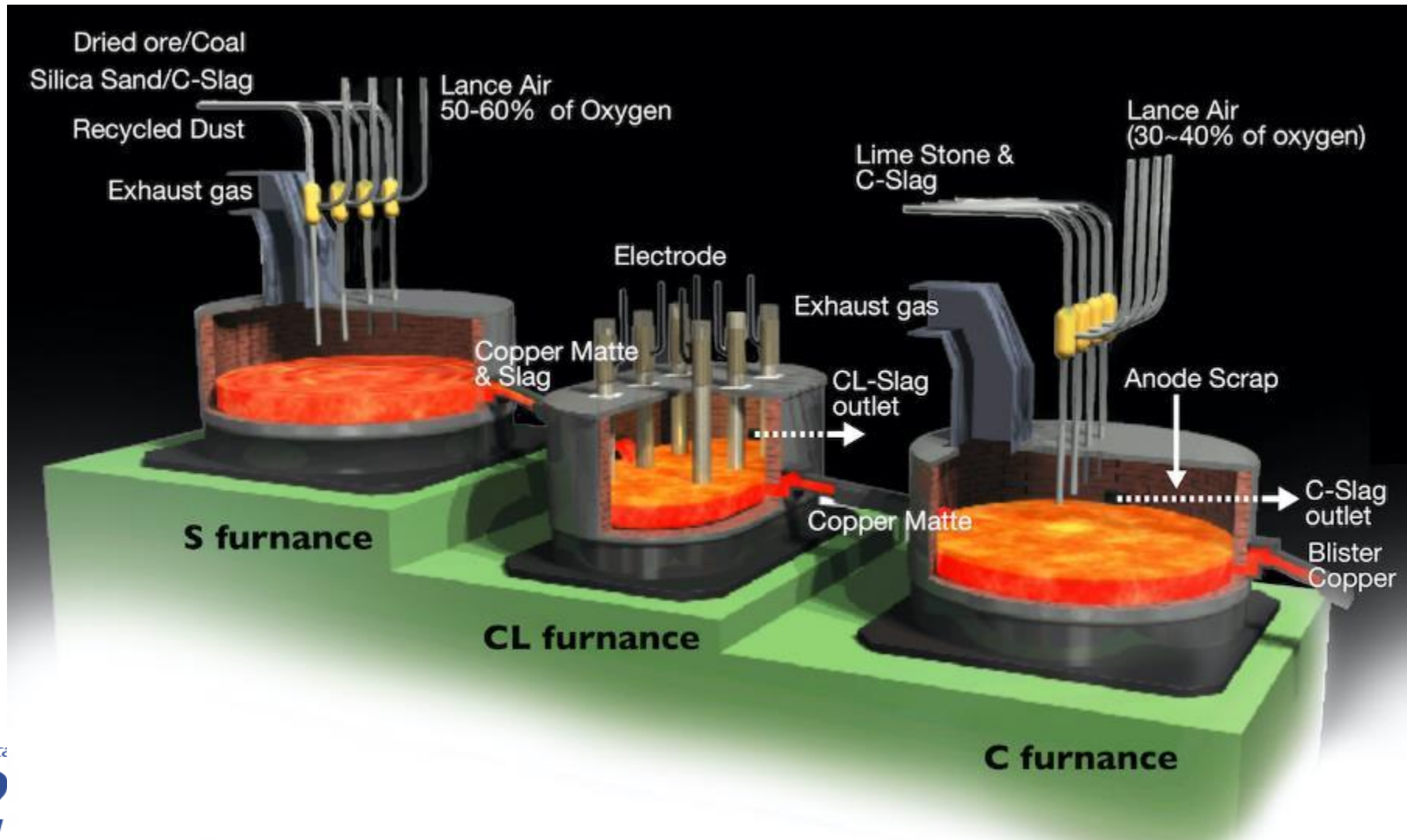

ILTEC Technology

Considerations and data required

- ◆ Thermal analysis (CFD) for heat flux from cooling elements
- ◆ Cooling medium flow based on cooling element geometry and heat flux
- ◆ Pressure drop based on geometry and location of cooling system
- ◆ Temperature increase based on heat flux and cooling medium flow

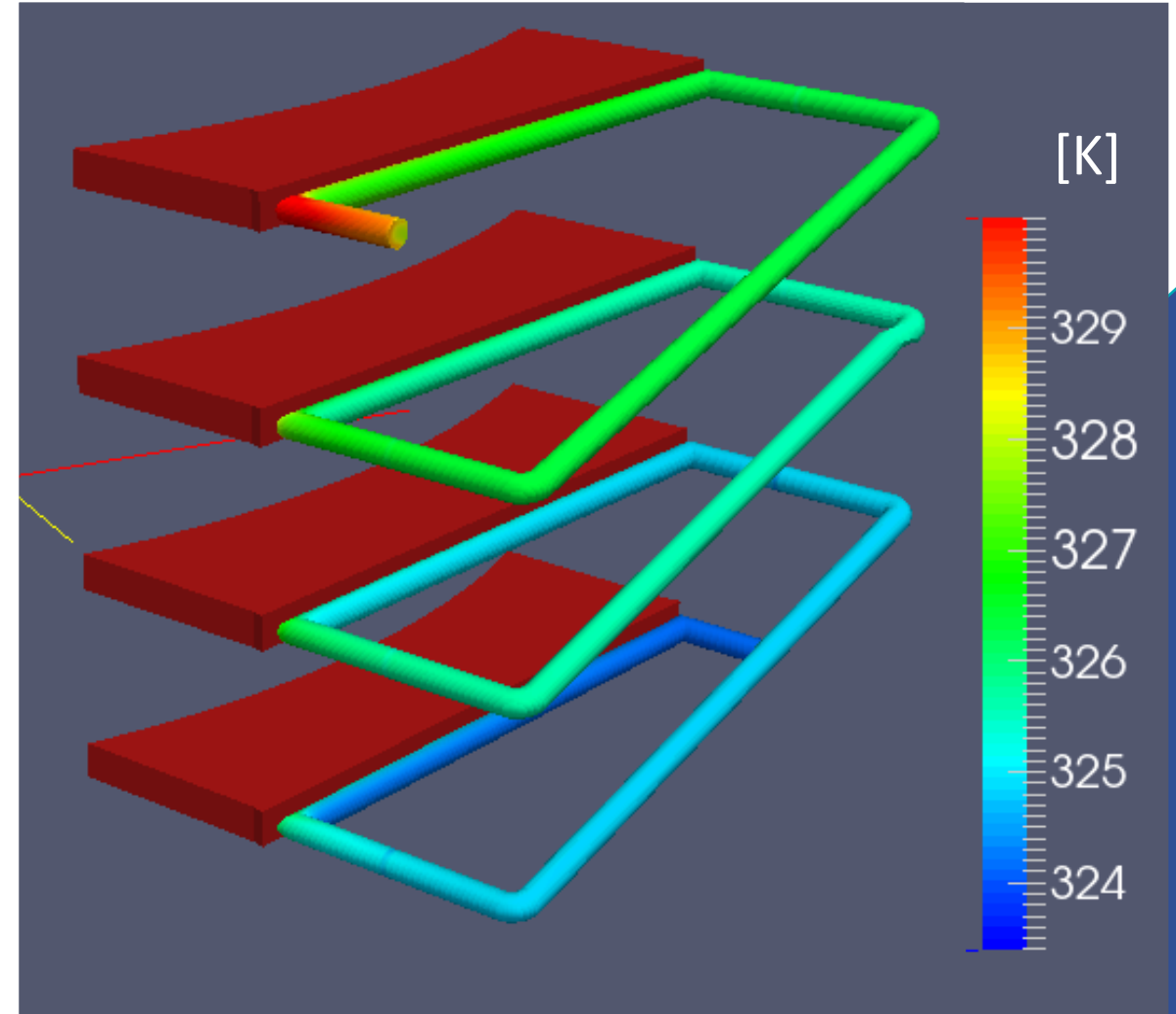

ILTEC Technology Solution for Mitsubishi furnace

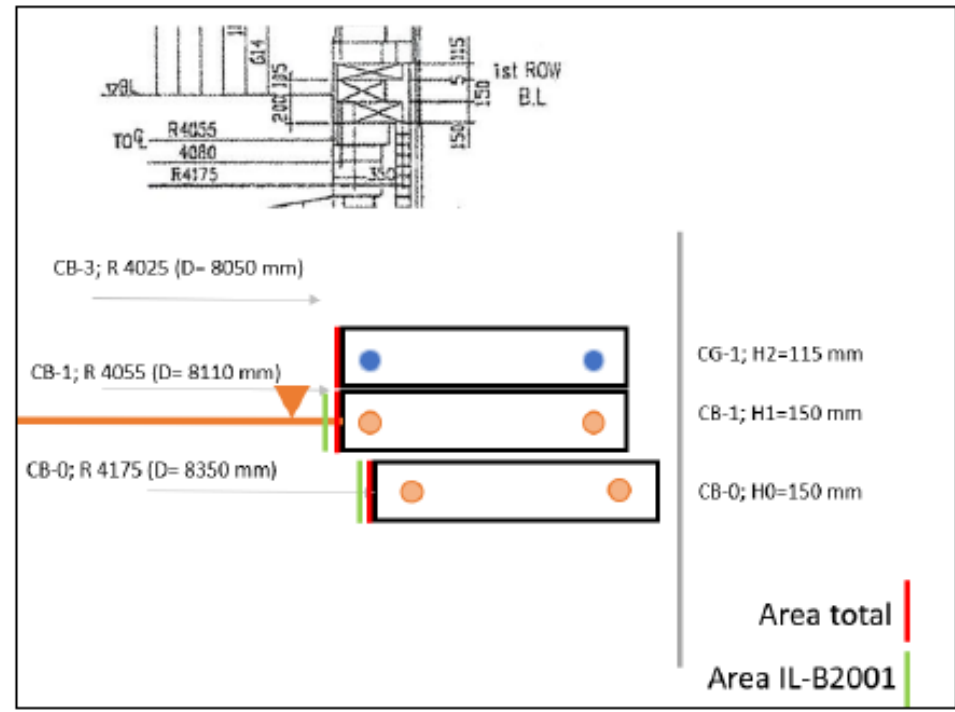
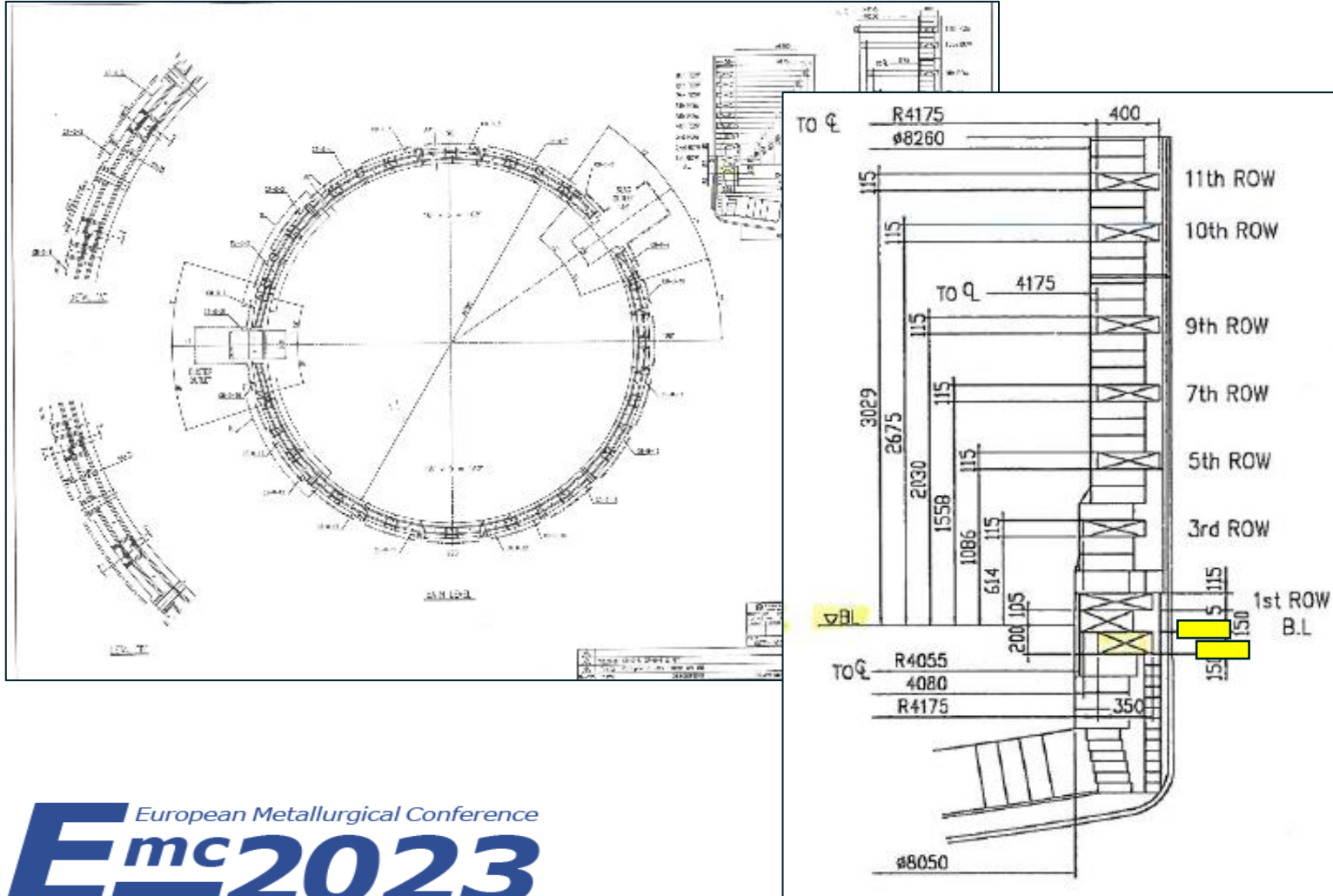

ILTEC Technology

Solution for Mitsubishi furnace

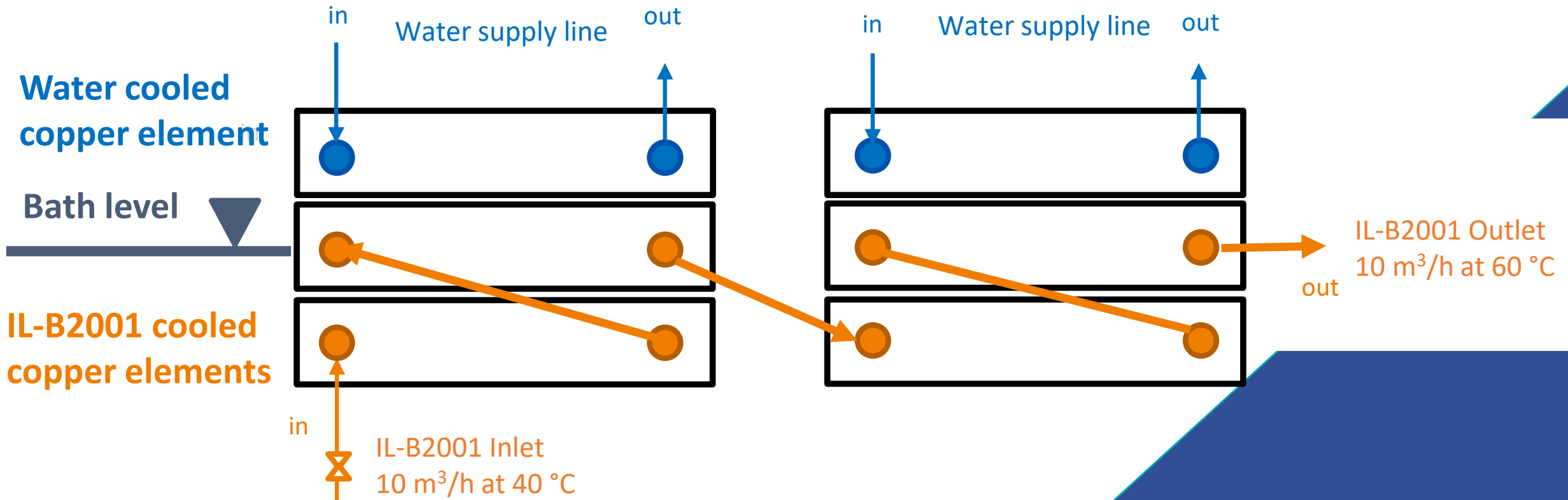

ILTEC Technology

From the idea to paper

- ◆ Pump rack: DN125; 7 bar pressure drop for 100 m³/h (pump capacity) and 3000 liter tank volume
- ◆ Heat exchanger rack: heat exchanger capacity 1 000 kW each (for peak heat load both in use)
- ◆ 2x Distribution unit: 6x supply lines (each) with DN 40 incl. flow, temperature and pressure measurement

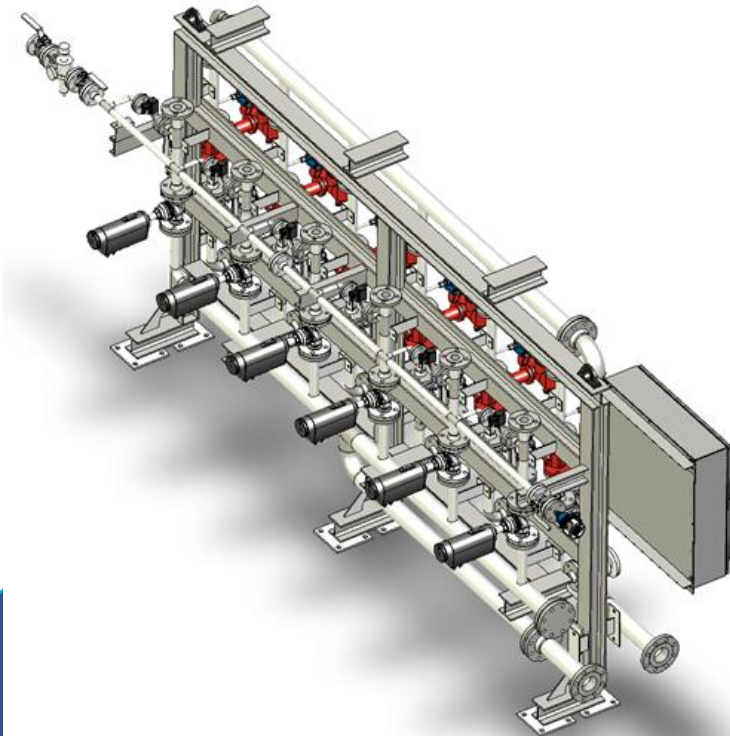
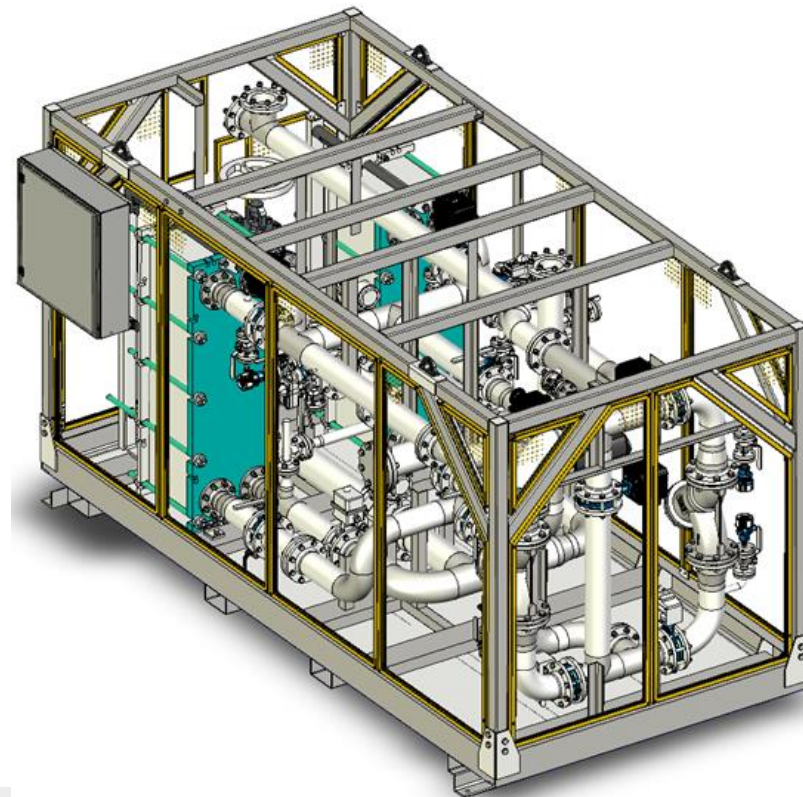
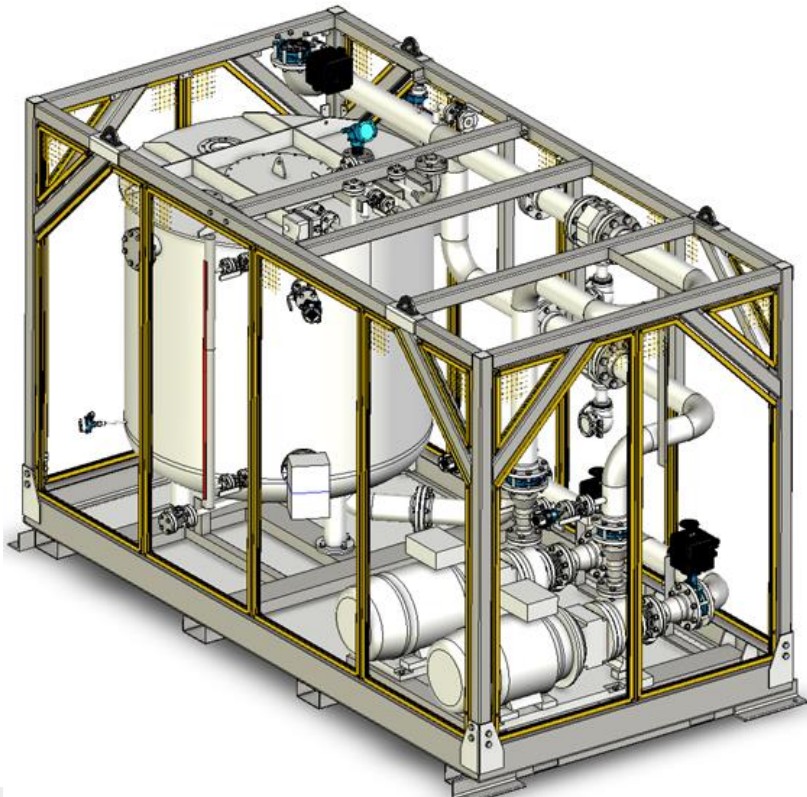

ILTEC Technology

State-of-the-art assembly

- ◆ Fully assembled system
- ◆ Fully wired and incl. programming (stand alone solution with possibility of implementation to PLC)
- ◆ Factory acceptance tested (FAT)



ILTEC Technology

A smart system brought to life

- ◆ Leak detection of individual supply lines - automated purging of single lines
- ◆ Overall leak detection via continuous level measurement
- ◆ Stable and uniform freeze lining via heat flux optimization: By regulation of the flow, the uniform temperature profile can be adjusted (within certain boundaries) all around the circumference of the furnace.



ILTEC Technology

Think out of the box – Any other ideas?





METTOP GmbH

Peter-Tunner-Strasse 4
8700 Leoben
Austria

Contact

Dr. Martina Hanel
+43 664 88 60 45 50
Martina.hanel@mettop.com

